

A182 F316L Weld Neck Flange, 10 Inch

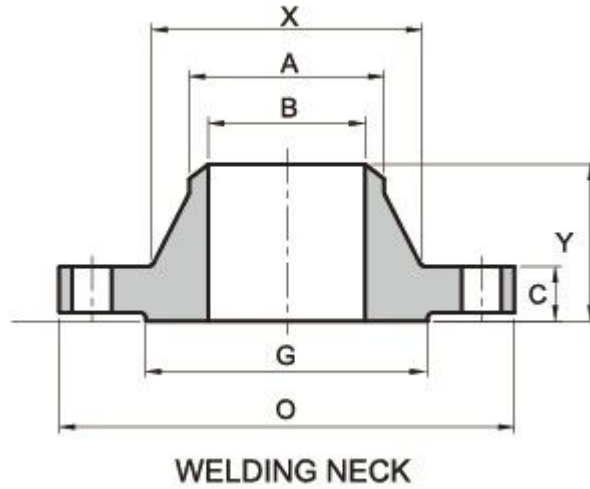

Pipe Normal Diam.		O.D. Flange	Thk. Of Flange Min	Diam. of Hub	Diameter of Raised Face	Hub Diam. Chamfer of W.N	Length of Hub	Diam. of Bolt Circle	Diam. of Bolt Holes	Number of Bolts	Diam. of Bolts (inch)	Approx. Weight	
inch	dn	O	C	X	G	A	Y	BC	BH	BN	BD	KG/PCS	LB/PCS
1/2"	15	95.5	14.2	38.1	35.1	22.4	52.3	66.5	15.7	4	1/2"	0.9	2
3/4"	20	117.5	15.7	47.8	42.9	25.4	57.2	82.6	19.1	4	5/8"	1.6	3.5
1"	25	124.0	17.5	53.8	50.8	26.9	62	88.9	19.1	4	5/8"	1.9	4.2
1-1/4"	32	133.5	20.6	63.5	63.5	28.4	66.5	98.6	19.1	4	5/8"	2.6	5.8
1-1/2"	40	155.5	22.4	69.9	73.2	31.8	69.9	114.3	22.4	4	3/4"	3.6	8
2"	50	165.0	25.4	84.1	91.9	36.6	73.2	127	19.1	8	5/8"	4.7	10.4
2-1/2"	65	190.5	28.4	100.1	104.6	41.1	79.2	149.4	22.4	8	3/4"	4.8	15
3"	80	209.5	31.8	117.3	127	46	82.6	168.1	22.4	8	3/4"	8.7	19.3
3-1/2"	90	228.5	35.1	133.4	139.7	49.3	85.9	184.2	25.4	8	7/8"	11.6	25.5
4"	100	273.0	38.1	152.4	157.2	53.8	101.6	215.9	25.4	8	7/8"	18.4	40.5
5"	125	330.0	44.5	189	185.7	60.5	114.3	266.7	28.4	8	1"	31	68
6"	150	355.5	47.8	222.3	215.9	66.5	117.3	292.1	28.4	12	1"	37	81.4
8"	200	419.0	55.6	273.1	269.7	76.2	133.4	349.3	31.8	12	1 1/8"	54.5	120
10"	250	508.0	63.5	342.9	323.9	85.9	152.4	431.8	35.1	16	1 1/4"	98.5	195
12"	300	559.0	66.5	400.1	381	91.9	155.4	489	35.1	20	1 1/4"	105	231
14"	350	603.5	69.9	431.8	412.8	93.7	165.1	527.1	38.1	20	1 3/8"	150	330
16"	400	686.0	76.2	495.3	469.9	106.4	177.8	603.3	41.1	20	1 1/2"	177	390
18"	450	743.0	82.6	546.1	533.4	117.3	184.2	654.1	44.5	20	1 5/8"	228	503
20"	500	813.0	88.9	609.6	584.2	127	190.5	723.9	44.5	24	1 5/8"	285	628
24"	600	940.0	101.6	717.6	692.2	139.7	203.2	838.2	50.8	24	1 7/8"	372	820

Sourcing: <http://www.landeeflange.com/>

Landeeflange.com has won fully trust from clients by providing the best flanges. Our service mission is to achieve 100% customer satisfaction.