

Forged Steel Golden Weld Neck Flange, 900LB

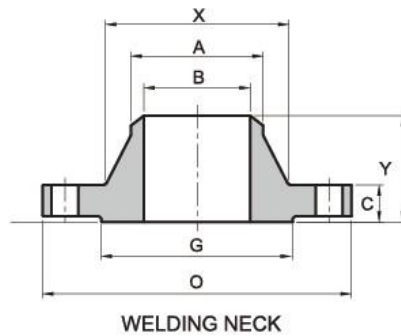

Flange Normal Diam.		O.D. Flange	Thk. Of Flange Min	Diam. of Hub	Hub Diam. Chamfer of W.N	Length Hub	Diam. of Bolt Circle	Diam. of Bolt Holes	Number of Bolts	Diam. of Bolts (inch)	Approx. Weight	
inch	dn	O	C	X	A	Y	BC	BH	BN	BD	KG/PCS	LB/PCS
1/2"	15	120.7	22.4	38.1	21.3	60.5	82.6	22.4	4	3/4"	2.1	4.6
3/4"	20	130	25.4	44.5	26.7	69.9	88.9	22.4	4	3/4"	2.7	5.9
1"	25	149.4	28.4	52.3	33.5	73.2	101.6	25.4	4	7/8"	3.9	8.6
1-1/4"	32	158.8	28.4	63.5	42.2	73.2	111.3	25.4	4	7/8"	4.5	9.9
1-1/2"	40	177.8	31.8	69.9	48.3	82.6	124	28.4	4	1"	6.2	13.7
2"	50	215.9	38.1	104.6	60.5	101.6	165.1	25.4	8	7/8"	11.3	24.9
2-1/2"	65	244.3	41.1	124	73.2	104.6	190.5	28.4	8	1"	16.3	36
3"	80	241.3	38.1	127	88.9	101.6	190.5	25.4	8	7/8"	15	33
4"	100	292.1	44.5	158.8	114.3	114.3	235	31.8	8	1 1/8"	24	52.8
5"	125	349.3	50.8	190.5	141.2	127	279.4	35.1	8	1 1/4"	38.5	85
6"	150	381	55.6	235	168.4	139.7	317.5	31.8	12	1 1/8"	50	110
8"	200	469.9	63.5	298.5	219.2	162.1	393.7	38.1	12	1 3/8"	85	187
10"	250	546.1	69.9	368.3	273.1	184.2	469.9	38.1	16	1 3/8"	123	271
12"	300	609.6	79.2	419.1	323.9	200.2	533.4	38.1	20	1 3/8"	168	370
14"	350	641.4	85.9	450.9	355.6	212.9	558.8	41.1	20	1 1/2"	198	436
16"	400	704.9	88.9	508	406.4	215.9	616	44.5	20	1 5/8"	225	495
18"	450	787.4	101.6	565.2	457.2	228.6	685.8	50.8	20	1 7/8"	318	701
20"	500	857.3	108	622.3	508	247.7	749.3	53.8	20	2"	376	829
24"	600	1041	139.7	749.3	609.6	292.1	901.7	66.5	20	2 1/2"	680	1498

Source: <http://www.landeeflange.com>

Landeeflange.com has won fully trust from clients by providing the best flanges. Our service mission is to achieve 100% customer satisfaction.